



Ditec VALOR HH-HS

IP2063EN
Technical manual

Sliding doors automation for
hospitals and heavy sliding doors
(Translation of the original instructions)

Index

	Subject	Page
1.	General safety precautions	25
2.	Declaration of incorporation of partly completed machinery	26
2.1	Machinery Directive	26
3.	Technical specifications	27
3.1	Operating instructions	27
4.	Standard installation	28
5.	VALORHH box fastening	29
6.	VALORHS box fastening	31
7.	VALORHH door wing installation and adjustment	33
8.	VALORHS door wing installation and adjustment	34
9.	Floor guide installation	35
10.	Belt adjustment	36
11.	Lock device installation	37
12.	Connection of power supply	38
13.	Routine maintenance plan	39

Caption



This symbol indicates instructions or notes regarding safety issues which require particular attention.



This symbol indicates informations which are useful for correct product function.

1. General safety precautions

 This installation manual is intended for qualified personnel only.
Installation, electrical connections and adjustments must be performed in accordance with Good Working Methods and in compliance with applicable regulations.

Before installing the product, carefully read the instructions. Bad installation could be hazardous. The packaging materials (plastic, polystyrene, etc.) should not be discarded in the environment or left within reach of children, as these are a potential source of hazard.

Before installing the product, make sure it is in perfect condition.

Do not install the product in an explosive environment and atmosphere: gas or inflammable fumes are a serious hazard risk.

Before installing the motors, make all structural changes relating to safety clearances and protection or segregation of all areas where there is risk of being crushed, cut or dragged, and danger areas in general.

Make sure the existing structure is up to standard in terms of strength and stability. The motor manufacturer is not responsible for failure to use Good Working Methods in building the frames to be motorized or for any deformation occurring during use.

The safety devices (photocells, safety edges, emergency stops, etc.) must be installed taking into account: applicable laws and directives, Good Working Methods, installation premises, system operating logic and the forces developed by the motorized door.

The safety devices must protect any areas where the risk exists of being crushed, cut or dragged, or where there are any other risks generated by the motorized door.

Apply hazard area notices required by applicable regulations.

Each installation must clearly show the identification details of the motorized door.

 When necessary, connect the motorized door to a reliable earth system made in accordance with applicable safety regulations.

During installation, maintenance and repair, interrupt the power supply before opening the lid to access the electrical parts.

The protective casing of the automation must be removed by qualified personnel only.

 To handle electronic parts, wear earthed antistatic conductive bracelets. The motor manufacturer declines all responsibility in the event of component parts being fitted that are not compatible with the safe and correct operation.

For repairs or replacements of products only original spare parts must be used. The installer shall provide all information relating to automatic, manual and emergency operation of the motorized door, and provide the user with operating instructions.

2. Declaration of incorporation of partly completed machinery

(Directive 2006/42/EC, Annex II-B)

The manufacturer Entrematic Group AB with headquarters in Lodjursgatan 10, SE-261 44 Landskrona, Sweden

declares that the automation system for Ditec VALOR HH-HS sliding doors:

- has been constructed to be installed on a manual door to construct a machine pursuant to the Directive 2006/42/EC. The manufacturer of the motorized door shall declare conformity pursuant to the Directive 2006/42/EC (annex II-A), prior to the machine being put into service;
- conforms to applicable essential safety requirements indicated in annex I, chapter 1 of the Directive 2006/42/EC;
- conforms to the Low Voltage Directive 2006/95/EC;
- conforms to the Electromagnetic Compatibility Directive 2004/108/EC;
- technical documentation conforms to Annex VII-B to the Directive 2006/42/EC;
- technical documentation is managed by Marco Pietro Zini with offices in Via Mons. Banfi, 3 - 21042 Caronno Pertusella (VA) - ITALY;
- a copy of technical documentation will be provided to national competent authorities, following a suitably justified request.

Landskrona, 15-01-2013

Marco Pietro Zini
(President)

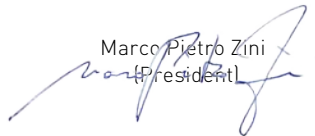

2.1 Machinery Directive

Pursuant to Machinery Directive (2006/42/EC) the installer who motorizes a door or gate has the same obligations as the manufacturer of machinery and as such must:

- prepare the technical file which must contain the documents indicated in Annex V of the Machinery Directive;
(The technical file must be kept and placed at the disposal of competent national authorities for at least ten years from the date of manufacture of the motorized door);
- draw up the EC Declaration of Conformity in accordance with Annex II-A of the Machinery Directive and deliver it to the customer;
- affix the EC marking on the motorized door in accordance with point 1.7.3 of Annex I of the Machinery Directive.

3. Technical details

	VALORHH	VALORHS
Power supply	230 V~ 50/60 Hz	230 V~ 50/60 Hz
Absorption	1 A	1 A
Maximum speed 1 wing	0.5 m/s	0.5 m/s
Maximum speed 2 wings	1.0 m/s	1.0 m/s
Service class	4 - INTENSE 5 - VERY INTENSE	4 - INTENSE 5 - VERY INTENSE 6 - CONTINUOUS
Intermittence	class 4: S3=30% class 5: S3=60%	class 4: S3=30% class 5: S3=60% class 6: S3 = 100%
Maximum load 1 wing	class 4: 200 kg class 5: 160 kg	class 4: 200 kg class 5: 170 kg
Maximum load 2 wings	class 4: 200 kg class 5: 160 kg	class 4: 340 kg class 5: 300 kg
Maximum load 1 wing (2 wheels carriage)	/	class 5: 300 kg class 6: 220 kg
Maximum load 2 wings (2 wheels carriage)	/	class 5: 360 kg class 6: 300 kg
Maximum load 1 wing (3 carriages)	/	class 4: 450 kg class 5: 350 kg
Maximum load 2 wings (3 carriages)	/	class 4: 500 kg class 5: 400 kg
Temperature	min +2 °C max +55 °C	min -20 °C max +55 °C
Temperature with batteries	min +2 °C max +50 °C	min -10 °C max +50 °C
Degree of protection	FOR INTERNAL USE ONLY	FOR INTERNAL USE ONLY
Control panel	EL32	EL32

3.1 Operating instructions

Service class: 4 (minimum 10÷5 years of working life with 100÷200 cycles per day).

Applications: INTENSE (for apartment block, commercial and healthcare entrances with intense pedestrian use).

Service class: 5 (minimum 5 years of working life with 600 cycles per day).

Applications: VERY INTENSE (for shared entrances with very intense pedestrian use).

Service class: 6 (minimum 5 years of working life with continuous use).

Applications: CONTINUOUS (for all special situations with continuous use).

- Performance characteristics are to be understood as referring to the recommended weight (approx. 2/3 of maximum permissible weight). When used with the maximum permissible weight a reduction in the above mentioned performance can be expected.
- Service class and the number of consecutive cycles are to be taken as merely indicative Having been statistically determined under average operating conditions, and are therefore not necessarily applicable to specific conditions of use.
- Each automatic entrance has variable elements such as: friction, balancing and environmental factors, all of which may substantially alter the performance characteristics of the automatic entrance or curtail its working life or parts thereof (including the automatic devices themselves). The installer should adopt suitable safety conditions for each particular installation.

4. Standard installation

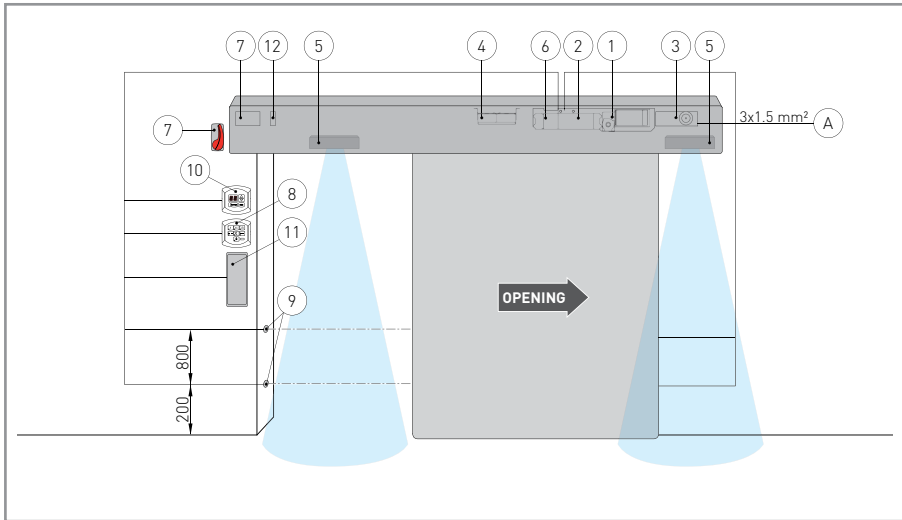

Ref.	Code	Description
1		Control and drive unit
2	EL32	Control panel
3	AL3	Power supply
4	VALHABC VALHABE	Continuous mode battery kit Emergency battery kit
5	PASAT3 PASAT3IH	External safety sensor Safety sensor built into automation (IP4X)
6	MP1	Accessory and supplementary functions connection module
7	VALHSLOK LOKSBM	Blocking device (VALORHS only) Release handle
8	COME COMH COMK	Function selector switch
9	CELPR	Photocells
10	MD1+MDA	Display module for diagnostics and advanced controls
11	PPF1 PPF2	Open button
12	VALHHFM	Magnetic door closed limit switch
A		Connect the power supply to an approved omnipolar switch with an opening distance of the contacts of at least 3mm (not supplied). The connection to the mains must be made via an independent channel, separated from the connections to command and safety devices.



NOTE: the given operating and performance features can only be guaranteed with the use of DITEC accessories and safety devices.

5. VALORHH box fastening

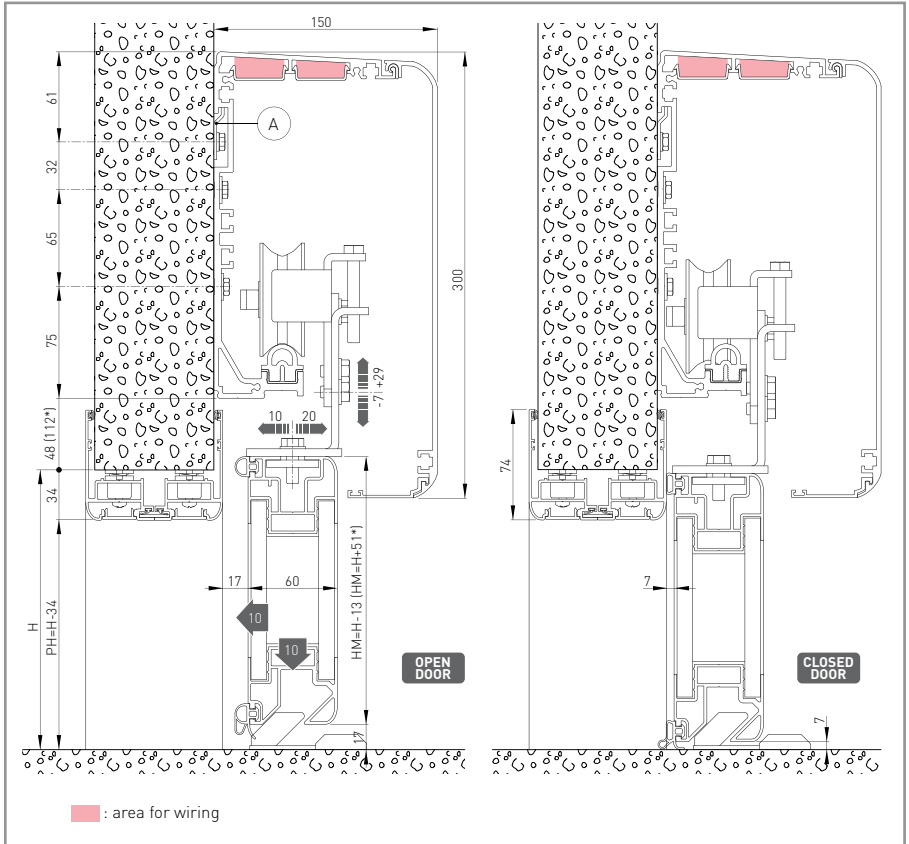

All of the measurements shown are expressed in millimetres (mm) unless otherwise indicated.

With the VALORHH automation units, when the door is at the completely closed position, it drops 10 mm and draws closer to the counter frame by 10 mm, causing the compression of the gaskets and thereby obtaining a hermetic seal.

In the figure there are the measurement units for wall installation of the VALORHH automation units, considering that the doors have been made of DITEC profiles series PAMH60.

If the PAMH60 door wing has lead-shielding (e.g. radiology department) refer to the measurements marked [*].

Attach the box with M6Ø12 steel plug or else with 6MA screws. Distribute the attachment points at about every 800 mm.

To make installation easier, supplied mounting brackets [A] can be used.

Verify that the back of the box is perpendicular to the floor and not deformed in a longitudinal sense with respect to the form of the wall. If the wall were to be not perfectly straight and smooth it is necessary to arrange the attachment of metal plates to which the box will then be attached.



WARNING: the box must be securely fixed to the wall using a fastening that is suitable for the weight of the door wings.

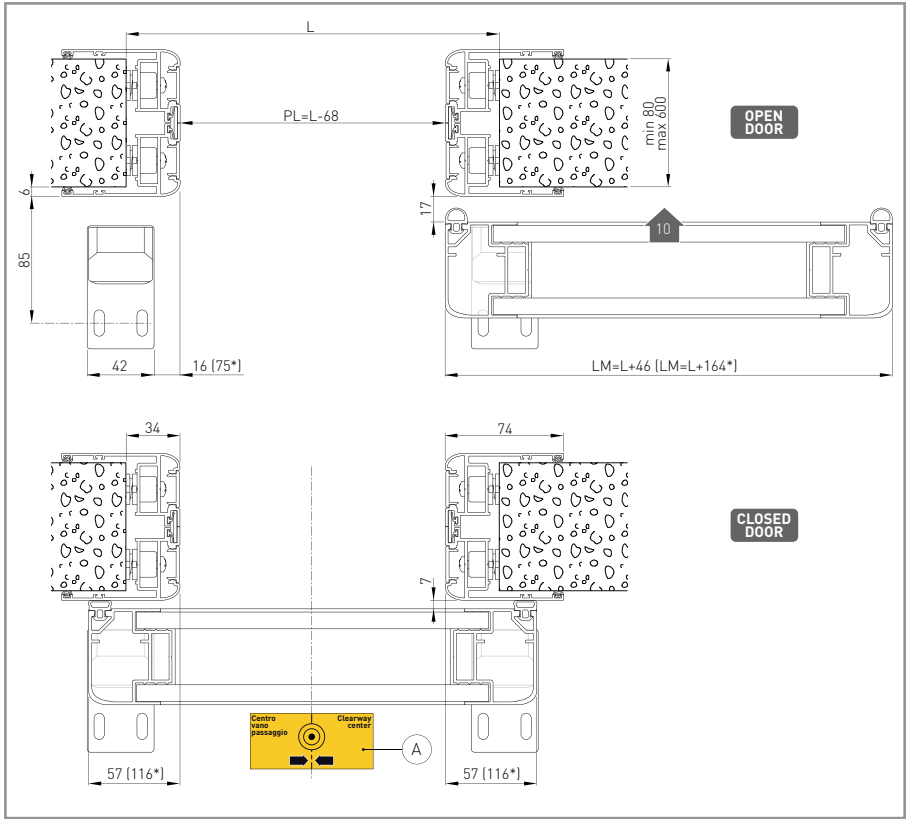

WARNING: fasten the automation to the wall so that the label [A] on the box coincides with the centre of the doorway.

6. VALORHS box fastening

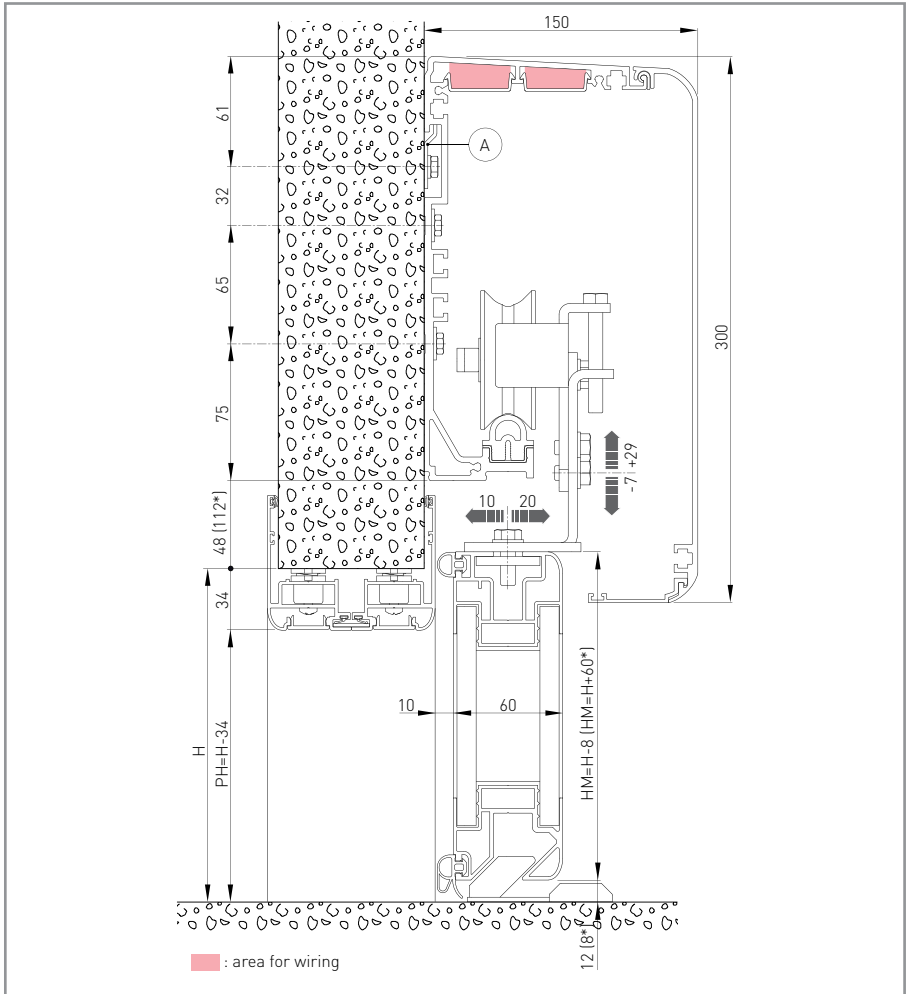

All of the measurements shown are expressed in millimetres (mm) unless otherwise indicated. In the figure there are the measurement units for wall installation of the VALORHS automation units, considering that the doors have been made of DITEC profiles series PAMH60. If the PAMH60 door wing has lead-shielding (e.g. radiology department) refer to the measurements marked [*]. Attach the box with M6Ø12 steel plug or else with 6MA screws. Distribute the attachment points at about every 800 mm. To make installation easier, supplied mounting brackets [A] can be used. Verify that the back of the box is perpendicular to the floor and not deformed in a longitudinal sense with respect to the form of the wall. If the wall were to be not perfectly straight and smooth it is necessary to arrange the attachment of metal plates to which the box will then be attached.



WARNING: the box must be securely fixed to the wall using a fastening that is suitable for the weight of the door wings.

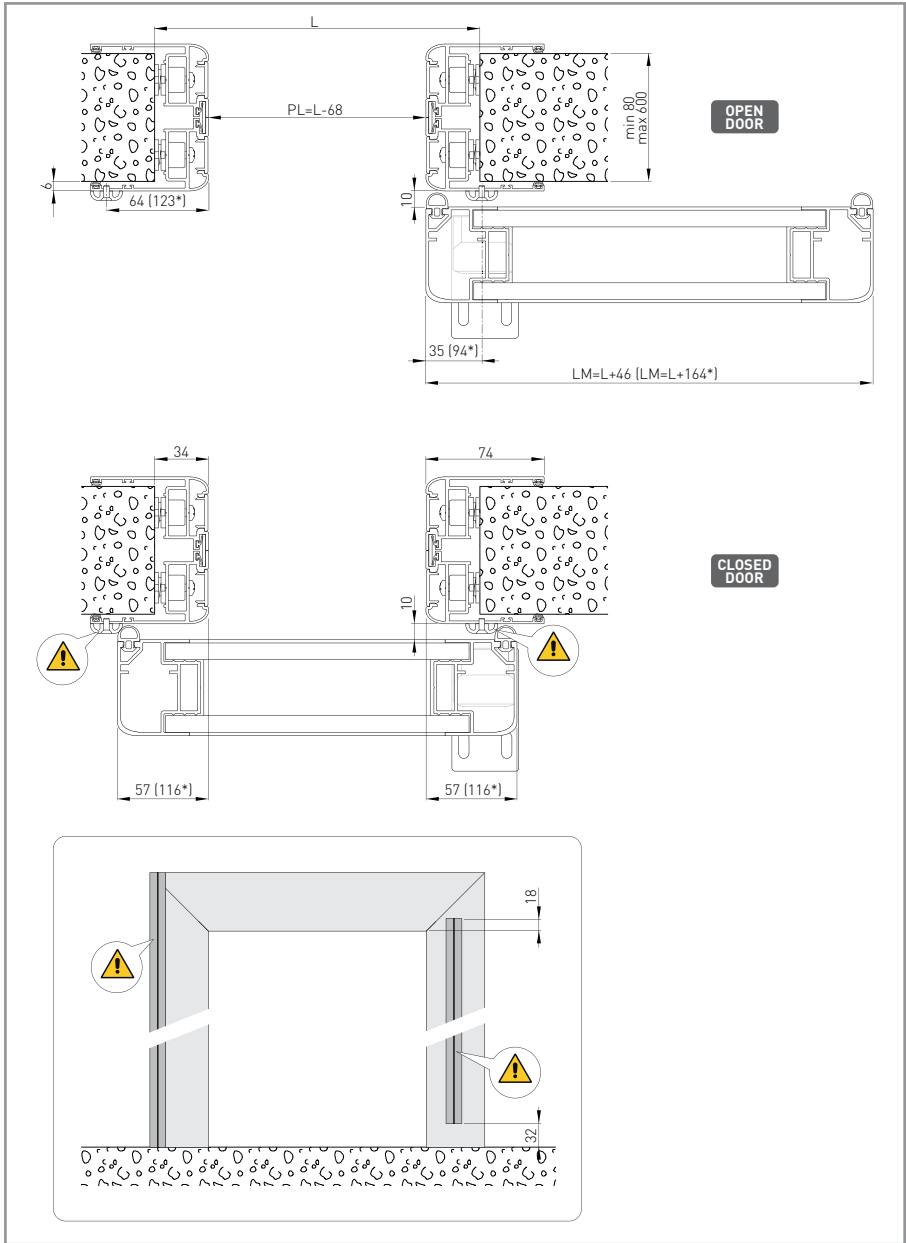

NOTE: the figure refers to doors that open to the right. For doors that open to the left, the position of the door stop profiles must be reversed.

7. VALORHH door wing installation and adjustment

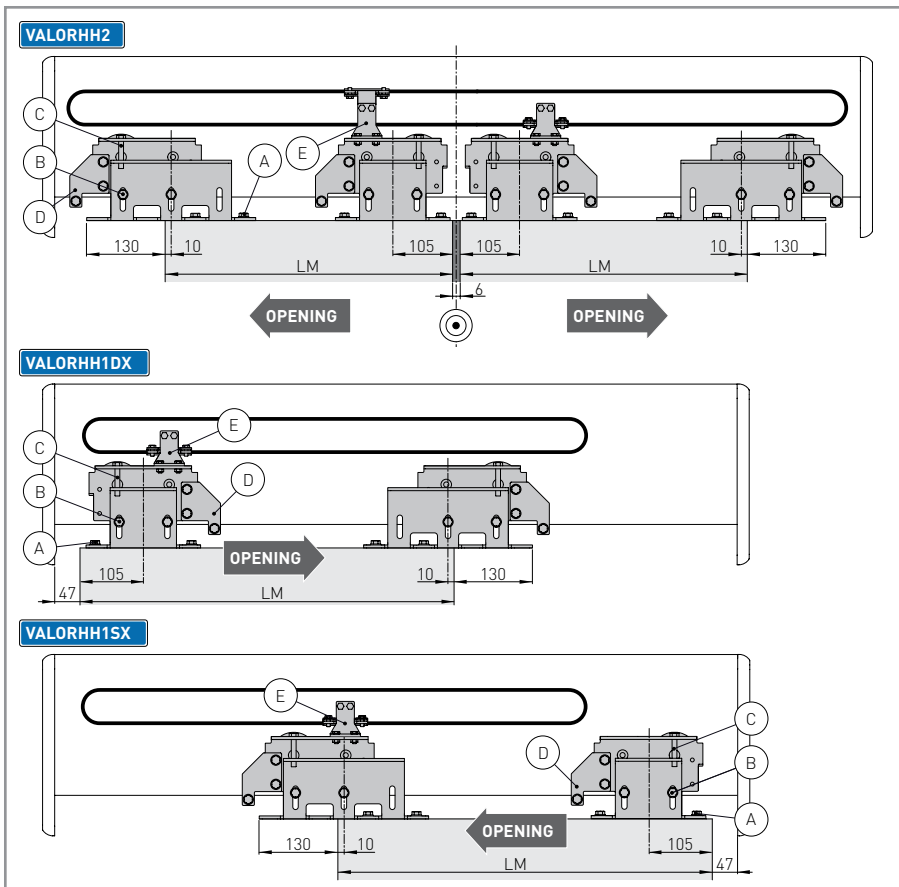

- Fix the carriages to the door wing using the screws [A] complying with the measurements shown in figure VALORHH2 for double-door wing automations, VALORHH1DX for single-door automations with opening to the right and VALORHH1SX for single-door automations with opening to the left.
- Fit the pre-assembled door wing to the automation.
- Assemble the anti-derailing bracket [D] as indicated and adjust it so that it does not rub against the box. With the door wing closed, adjust the bracket [F] on the box so that the door wing cannot be lifted.
- Loosen screws [B], adjust the vertical position of the door wing using the screw [C] and fix the adjustment using screws [B];
- Move the door wing manually to check that it moves freely without friction.
- Check that the door wing is correctly lowered when fully closed and pushes against the counter frame.
- Fix the belt connecting bracket [E] to the carriage.

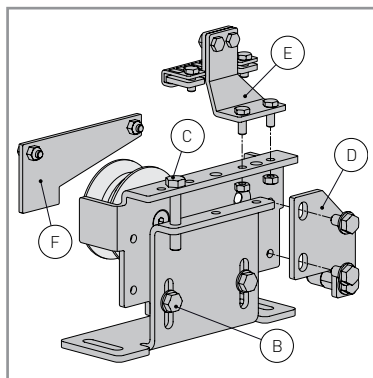

8. VALORHS door wing installation and adjustment

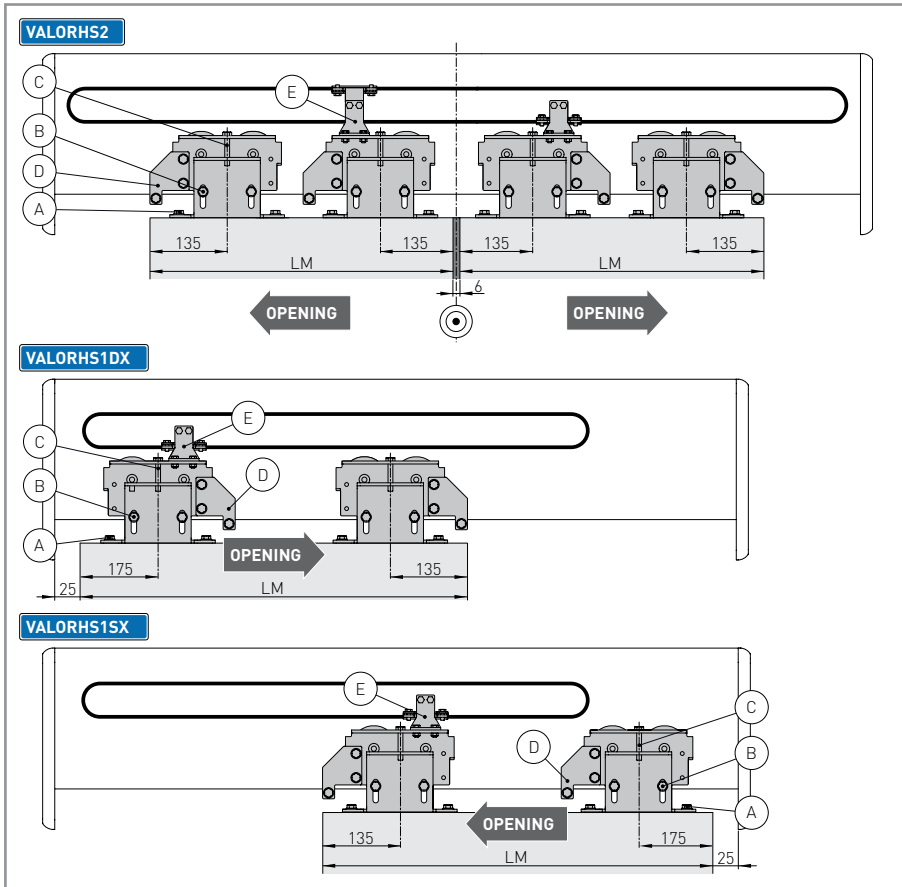

NOTE: if a second wheel [F] (KVALHS2RC kit) is added to increase the load bearing capacity of the automation, the adjustment screw [C] must be moved into a central position.

- Fix the carriages to the door wing using the screws [A] complying with the measurements shown in figure VALORHS2 for double-door wing automations, VALORHS1DX for single-door automations with opening to the right and VALORHS1SX for single-door automations with opening to the left.
- Fit the pre-assembled door wing to the automation.
- Assemble the anti-derailing bracket [D] as indicated and adjust it so that it does not rub against the anti-derailing bracket and the box.
- Loosen screws [B], adjust the vertical position of the door wing using screw [C] and fix the adjustment using screws [B].
- Move the door manually to check that it moves freely with-out friction.
- Fix the belt connecting bracket [E] to the carriage.

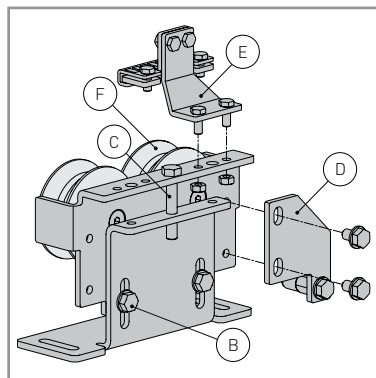

9. Floor guide installation

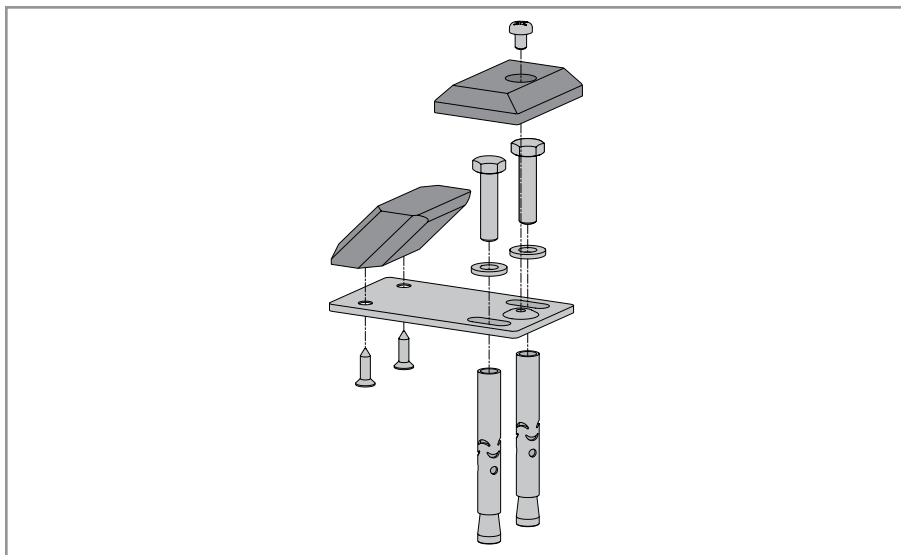

Install the floor guide for the PAMH60 door wing by complying with the measurements on page 8 [VALORHH], or on page 10 [VALORHS].



NOTE: with VALORHH automation units it is necessary to install 2 floor guides.

10. Belt adjustment

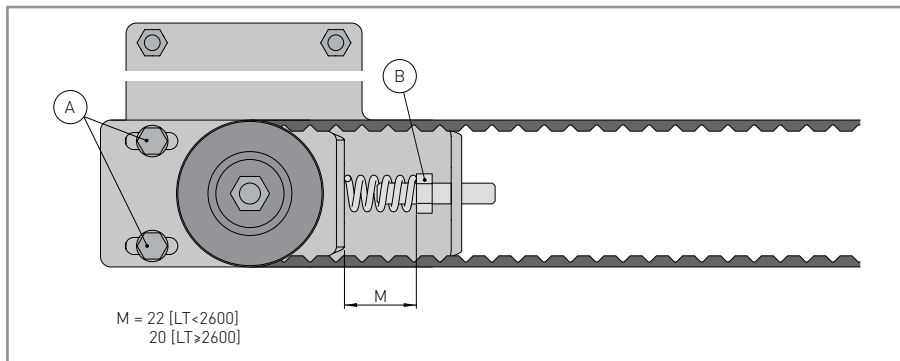

Loosen the screws [A], unscrew screw [B] until the spring compresses to 22 mm (if the length of the automation is less than 2600 mm) or 20 mm (if the length of the automation is more than 2600 mm).

Lock the adjustment by tightening screws [A].



WARNING: an incorrect adjustment prejudices the correct operation of the automation unit.

11. Lock device installation

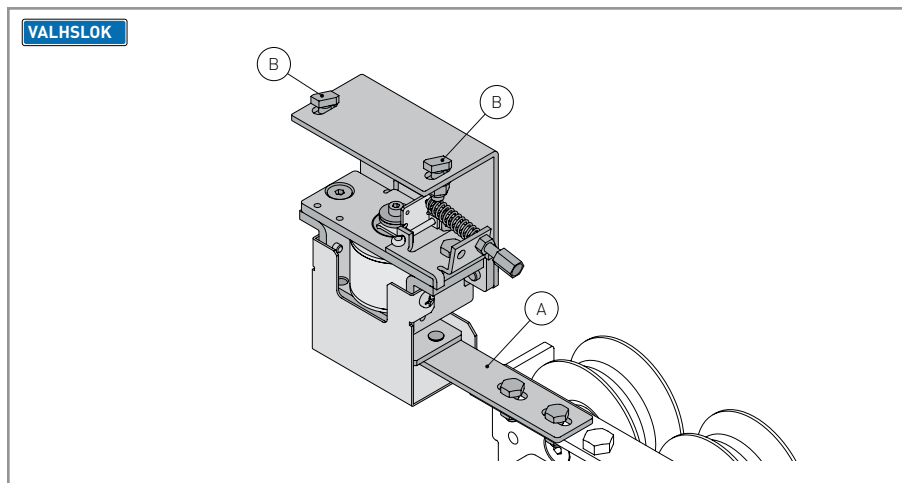

- Fix the block hook bracket [A] to the carriage.
- Bring the door wings to a closed position.
- Fasten the VALHSLOK blocking device (only on VALORHS automations) to the box profile using the screws [B] provided.
- Align the blocking pin and the block hook bracket [A] and manually check that it operates correctly.
- Lightly lubricate the blocking pin and the block hook bracket [A].

12. Connection of power supply

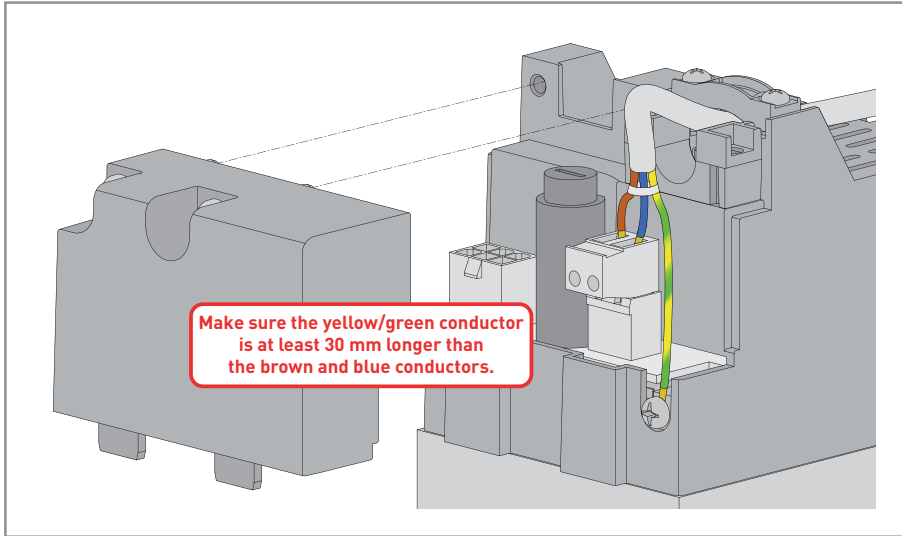

Before connecting the power supply, make sure the plate data correspond to that of the mains power supply.

An omnipolar disconnection switch with minimum contact gaps of 3 mm must be included in the mains supply.

Check that upstream of the electrical installation there is an adequate residual current circuit breaker and a suitable overcurrent cutout.

Use a H05RN-F 3G1,5 or H05RR-F 3G1,5 type electric cable and connect to the terminals L (brown), N (blue),  (yellow/green) in the automation. Make sure the yellow/green conductor is at least 30 mm longer than the brown and blue conductors.

Secure the cable using the special cable clamp and remove the outer sheath near the terminal only.

Connection to the mains power supply, in the section outside the automation, is made with independent channels and separated from the connections to the control and safety devices. The channels must penetrate a few centimetres inside the automation through a hole maximum $\varnothing 16$ mm.

Make sure there are no sharp edges that may damage the power supply cable.

Make sure that the mains power supply (230 V) conductors and the accessory power supply (24 V) conductors are separate.

13. Routine maintenance plan

Perform the following operations and checks every 6 months according to intensity of use of the automation.

Disconnect the 230 V~ power supply and batteries:

- Clean the moving parts (the carriage guides and the floor guides).
- Check the belt tension.
- Clean sensors and photocells.
- Check the stability of the automatic system and make sure that all screws are correctly tightened.
- Check the alignment of the doors, the closing positions and the correct introduction of the blocking device.

Reconnect the 230 V~ power supply and batteries:

- Check that the blocking system is working correctly.
- Check the stability of the door and that the movement is regular and without friction.
- Check that all control functions are operating correctly.
- Check that the photocells and safety sensors are operating correctly.
- Check that the door's developed powers are in accordance with applicable regulations.

On VALORHH automation with 160-200 kg door wing:

- Replace the carriage wheels every 3 years or 100,000 cycles.
- Replace the gearmotor every 5 years or 200,000 cycles.

On VALORHS automation with 360-500 kg door wing:

- Replace the gearmotor every 5 years or 500,000 cycles.



NOTE: for spare parts, see the spares price list.

All the rights concerning this material are the exclusive property of Entrematic Group AB.
Although the contents of this publication have been drawn up with the greatest care, Entrematic Group AB cannot be held responsible in any way for any damage caused by mistakes or omissions in this publication. We reserve the right to make changes without prior notice.
Copying, scanning and changing in any way are expressly forbidden unless authorised in writing by Entrematic Group AB.

ENTRE//MATIC



Entrematic Group AB
Lodjursgatan 10
SE-261 44, Landskrona
Sweden
www.ditecentrematic.com

